

# **FILL-RITE**<sup>®</sup>

**FUEL MANAGEMENT SYSTEM**



NXFM100 AND NXFM150

**MADE IN**  
**USA**   
WITH GLOBAL MATERIALS

**GR**  
GORMAN-RUPP  
COMPANY

**Table of Contents**

Compatibility / Specs..... 2  
 Online Account Setup..... 3  
 Warnings..... 3  
 NFPA Warnings..... 3  
 Wireless Warnings..... 3  
 Hazardous Area Examples..... 4  
 Site Survey / Where to Install..... 4  
 UL / cUL / CE..... 4  
 Certifications / Approvals..... 4  
 NXFM100 Wiring..... 4-5  
 Mounting Dimensions..... 6  
 NXFM100 Power On & Verification..... 6  
 NXFM150 Wiring..... 6-7  
 NXFM150 Power On & Verification..... 7

**Limited Warranty Policy**

Fill-Rite warrants the goods manufactured shall be free from defects of materials and workmanship. Specific warranty details for individual products can be found at [fillrite.com](http://fillrite.com).

**Privacy Statement**

Fill-Rite is committed to protecting user’s privacy. For more information about Fill-Rite FMS’s privacy policy, please review our full terms and conditions at [fillrite.com/fms](http://fillrite.com/fms).

**NXFM100 Compatibility & Specs**

Power Requirements	100-240V AC, 50/60Hz, 3600W 8-50V DC 1500W*
Pump Control Ratings	1HP 125V AC 2HP 240V AC 125V AC 30A General Purpose 240V AC 15A General Purpose 8-50V DC 30FLA/90LRA 8-50V DC 30A General Purpose
Dimensions	H: 8" W: 11.5" D: 5.75"
Weather Ratings	NEMA 4X / IP67
Temperature Ratings	-4° F to 122° F (-20° C to 50° C) UL Installations -40° F to 140° F (-40° C to 60° C) non-UL Installations
Pulsar	Power Supply: 12V DC, 100mA Rate: 1:1 to 10,000:1 Speed: 120,000 pulses per minute (2000Hz) Duty Cycle: 50% Contact: (example: reed switch, contact close) Open collector: (wiring example: 12V DC, signal, ground)

**Welcome to Fill-Rite® FMS! For tech support call: 833-483-5859**

**NXFM100 Site Controller**

This installation guide contains all of the information you need to install your hardware, create your online account, and begin using the Fill-Rite FMS.

Before beginning physical installation of your Fill-Rite FMS Site Controller, create an account at [fms.fillrite.com](http://fms.fillrite.com) and register your device’s serial number to your account. Physical installation cannot be completed without an online account being created.

If you’re using Fill-Rite FMS for the first time, we encourage you to run through the guided account setup by clicking the button in the top left of the Fill-Rite FMS homepage. This setup will walk you through the creation of your first site, upload drivers and vehicles, and orient you to the features of the Fill-Rite FMS web portal.

**NXFM150 Expansion Module**

This installation guide contains all of the information you need to install the Expansion Module hardware and expand your Fill-Rite FMS system.

The Fill-Rite FMS expansion system works in tandem with an installed Site Controller to increase the number of pumps you can monitor with Fill-Rite FMS. Ensure that you have completed installation of a Fill-Rite FMS Site Controller before installing your Expansion Module. This includes completing online account setup.

If you have any questions or need help with installation, contact your local Fill-Rite FMS distributor, visit [fillrite.com/fms](http://fillrite.com/fms), or call 833-483-5859.

**NXFM150 Compatibility & Specs**

Power Requirements	80-240V AC, 50/60Hz, 1810W 12V DC 95W†
Pump Control Ratings	80-240V AC 7.5A 12V DC 7.5A††
Dimensions	H: 12" W: 15.5" D: 5.25"
Weather Ratings	NEMA 4X / IP67
Temperature Ratings	-4° F to 122° F (-20° C to 50° C) UL Installations -40° F to 140° F (-40° C to 60° C) non-UL Installations
Pulsar	Power Supply: 12V DC, 100mA Rate: 1:1 to 10,000:1 Speed: 120,000 pulses per minute (2000Hz) Duty Cycle: 50% Contact: (example: reed switch, contact close) Open collector: (wiring example: 12V DC, signal, ground)

\*DC requires a Class 2 power source (see page 5)

†DC requires a Class 2 power source (see page 5)

††Ensure NXFM150 DC installations DO NOT exceed 7.5A

**Before Installation - Online Account Setup**

A [fms.fillrite.com](https://fms.fillrite.com) account serves as your dashboard to monitor your fuel, manage access permissions, run reports, and control the Fill-Rite FMS. Setting up an online account is easy, and is the first step to activating your Fill-Rite FMS.

Before installation, instruct your Fill-Rite FMS administrator to create a new account at [fms.fillrite.com](https://fms.fillrite.com) (if they have not already created one). The setup panel will guide administrators through getting their account online. To complete setup, administrators will need:

- The Serial Number of each piece of Fill-Rite FMS hardware being installed, found on the label inside the enclosure
- The street address of each site where Fill-Rite FMS hardware is being installed
- The tank dimensions at each site
- A driver list and vehicle list

**Create an Account at [fms.fillrite.com](https://fms.fillrite.com)**

Step 1: Go to [fms.fillrite.com](https://fms.fillrite.com) with any web browser and click the "Sign Up" button at the bottom of the screen

Step 2: Fill out your company and contact information, and click the "Sign Up" button

Step 3: In the top left corner of the page, underneath the Fill-Rite FMS logo, click the "Setup" button. The Setup page will walk you through all of the necessary steps and features to get your system going. A few of these steps are mandatory for installation, while others can be set up later. For install, here's what you need:

1. Add a Default Payment Method...**Tip:** Go to Settings > Billing in the left navigation
2. Add a Site...**Important:** Ensure that the location address and coordinates for the site are correct
3. Add a Tank...**Tip:** For installation and testing purposes, make sure you've added a tank to your installation site. All other details can be edited at anytime
4. Add Hardware and Configure Relay. Once you've added the hardware, go to Sites > Select a site > Select the "Configuration" tab > Click the settings icon for the relay you want to configure, then select "Configure Relay"...**Important:** To test the app, your Site Controller must be activated and the relay must be configured to your tank

**Before Installation - Hardware and Install Warnings**

Installations must be in accordance with the National Electrical Code: (NFPA No.70) and the code for Motor Fueling Dispensing Facilities and Repair Garages (NFPA No. 30A) The installer is responsible to investigate and follow any applicable state and local codes

**RESTRICTED ACCESS:** Access can only be gained by service persons or by users who have been instructed about the reasons for the restrictions applied to the location and about any precautions that shall be taken. Access is through the use of a tool, lock and key, or other means of security, and is controlled by the authority responsible for the location.

**Hazardous Area - Where not to mount Site Controller or Expansion Module**

**Do Not** mount the Site Controller, or any Fill-Rite FMS device within the hazardous / classified area: Class I Div 1 (Zone 1) or Class I Div 2 (Zone 2)

**Wireless Warnings**

The total wireless range of the Site Controller is 150'. To ensure the best performance of the Site Controller, do not install the Site Controller in a location where the signal can be blocked or degraded.

Dispensing Device	Class I Div 1 (Zone 1)	Class I Div 2 (Zone 2)
Compressed Natural Gas (CNG)	Entire space within the dispenser enclosure	1.5 m (5 ft) in all directions from the dispenser enclosure
Liquefied Natural Gas (LNG)	Entire space within the dispenser enclosure	3 m (10 ft) in all directions from the dispenser enclosure
Liquefied Petroleum Gas (LP-GAS)	Entire space within the dispenser enclosure; 450 mm (18 in) from the exterior surface of the dispenser enclosure to an elevation of 1.22 m (4 ft) above the base of the dispenser; the entire pit or open space beneath the dispenser and within 6 m (20 ft) horizontally from any edge of the dispenser when the pit or trench is not mechanically ventilated	Up to 450 mm (18 in) above ground and within 6 m (20 ft) horizontally from any edge of the dispenser enclosure, including pits or trenches within this area when provided with adequate mechanical ventilation

**Additional Warnings**

**Battery Replacement:** The Site Controller contains a rechargeable battery. If the battery needs to be replaced, please contact Fill-Rite or have an authorized technician service it.

**External Devices:** All peripheral equipment connected to the Site Controller or Expansion Module must be UL and cUL listed.

**Hazardous Area Examples**

**Classified Areas Adjacent to Dispensers**

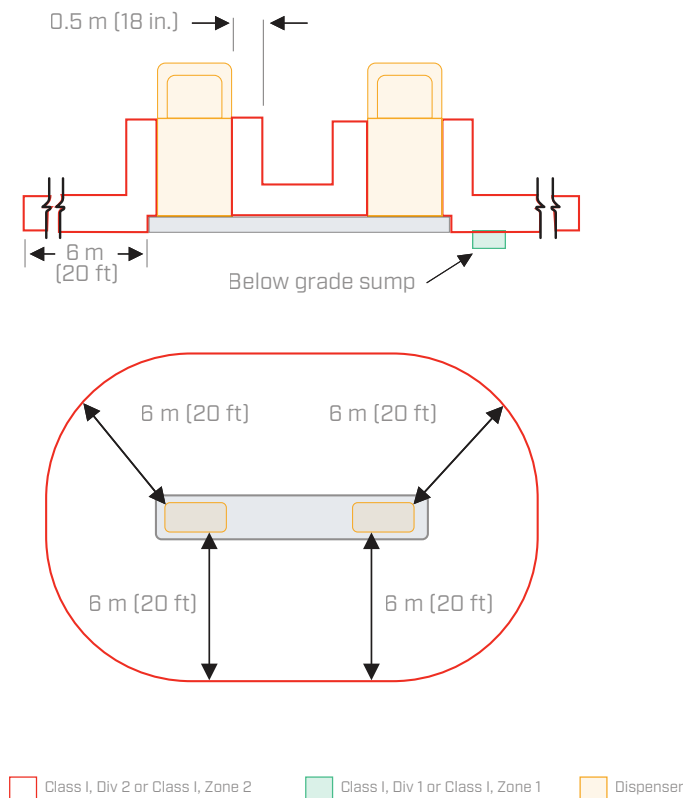

**Classified Areas Adjacent to Dispenser Mounted on Above-Ground Storage Tank**

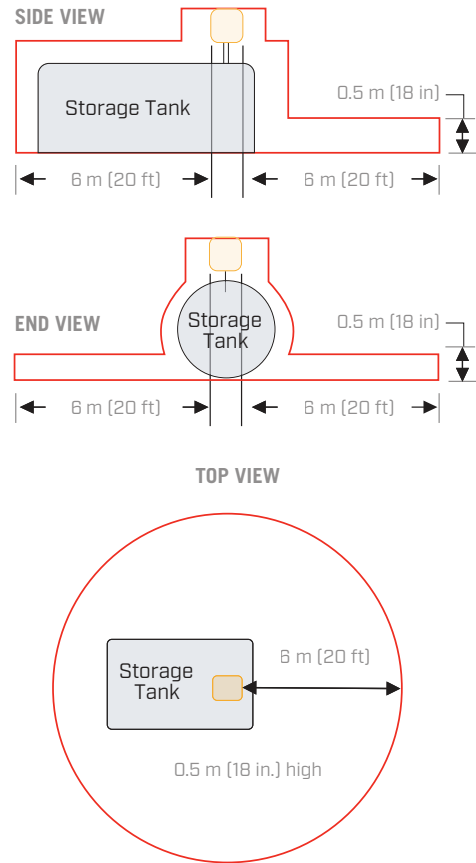

**Before Installation - Site Survey**

Complete the following steps before beginning installation of Fill-Rite FMS hardware. Failure to perform the below checks may result in the Fill-Rite FMS or fuel equipment being damaged or not working as intended.

1. Turn off all power to the pump and tank
2. Ensure that your installation location meets the following physical requirements:
  - Hardware will be mounted outside of hazardous zones - see warnings for more information
  - Hardware dimensions for mounting:  
 NXFM100 - 8" H x 11.5" W x 5.75" D  
 NXFM150 - 12" H x 15.5" W x 5.25" D
  - Installation location has clear line of site to pump, or is otherwise placed in location where wireless signal will not be blocked or degraded
  - Installation location has no wiring obstructions
3. Ensure that your site power supply and fuel equipment is compatible with Fill-Rite FMS's hardware. See Compatibility / Specs for more information
4. The Expansion Module needs to be physically connected to the Site Controller through shielded twisted pair RS-485 wire. The maximum distance the RS-485 connection is 5000 feet, however, the Wi-Fi range of the Site Controller is only 150 feet

**Hardware Installation NXFM100 Wiring**

**Fill-Rite FMS Hardware Power In / Power Out**

Fill-Rite FMS piggybacks power off of the AC input. Your wiring configuration will depend on whether the pump runs on AC or DC power. For use with DC applications, an additional Class 2 power supply is required for the board's power. (Class 2 as defined by UL 1238).

- a) Class 2 (Low-Voltage) - A circuit involving a potential of not more than 42.4 volts peak supplied by:
  1. An energy-limiting Class 2 transformer;
  2. A nonenergy-limiting Class 2 transformer and an overcurrent protective device that has been evaluated for limiting energy to Class 2 levels;
  3. The combination of an isolated transformer secondary winding and a fixed impedance or reliable regulating network which complies with the applicable performance requirements for an energy-limiting Class 2 transformer;
  4. A dry cell battery having output characteristics no greater than those of an energy-limiting Class 2 transformer; or
  5. The combination of a rechargeable battery and a fixed impedance or reliable regulating network which complies with the applicable performance requirements for an energy-limiting Class 2 transformer.



**Hardware Installation NXFM100 Wiring (continued)**

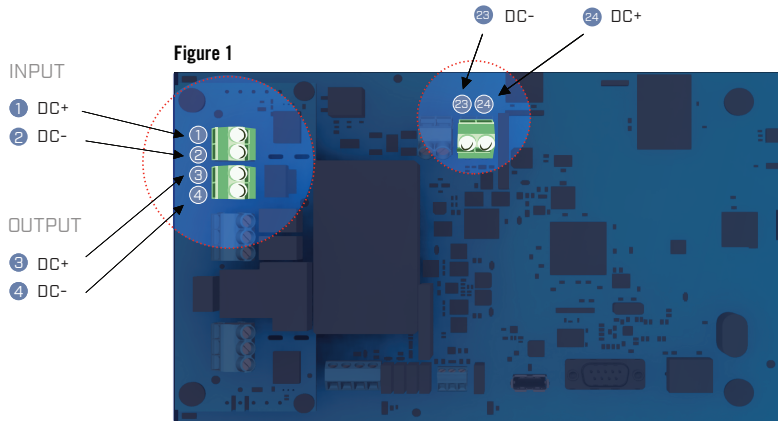

**DC**

DC power has 8-50V DC positive and negative wires. For power input, attach the appropriate wire to the designated terminals on the top bank of terminals on the Fill-Rite FMS board (see Figure 1).

For power output, attach the appropriate wire to the designated terminal on the bottom bank of terminals on the Fill-Rite FMS board as demonstrated in Figure 1.

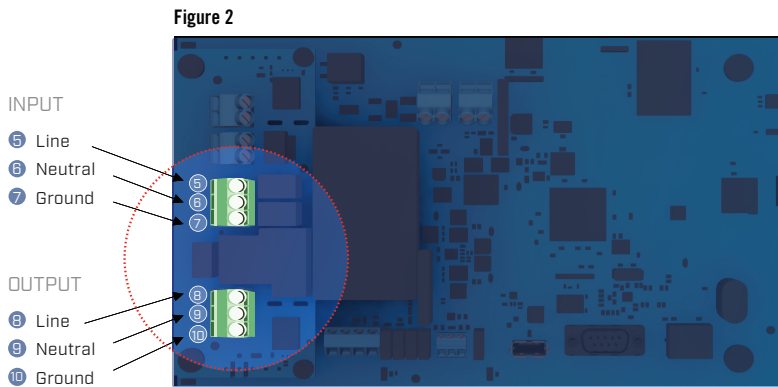

**AC**

AC power has a line, neutral, and ground wire. For power input, attach the appropriate wires to the designated terminal on the top bank of terminals of the Fill-Rite FMS board (see Figure 2).

For power output, attach the appropriate wires to the designated terminal on the bottom bank on terminals of the Fill-Rite FMS board as demonstrated in Figure 2.

**Hardware Installation - Pulsers - NXFM100**



**WARNING**

- Do not attach AC power to the terminal marked "12V DC". This terminal is for DC powered pulsers only. Attaching AC power to this terminal will destroy your Fill-Rite FMS board.

The wiring configuration for pulsers depends on whether you are using a 2 wire pulser or a 3 wire pulser. All pulser wiring should be connected to the terminals 12, 13, and 14 as demonstrated in the graphic below.

**2-Wire Pulser:**

For 2 wire pulsers, it does not matter which of the two wires you attach to each terminal:

- Attach one wire to the terminal marked 'Pulse' - Terminal (13)
- Attach one wire to the terminal marked 'GND' - Terminal (12)

**3-Wire Pulser:**

- Attach 12V power line from the pulser to the '12V+' terminal - Terminal (14)
- Attach signal wire to the 'Pulse' terminal - Terminal (13)
- Attach the ground wire to the 'GND' terminal - Terminal (12)
- For quadrature signal, use one leg of the signal only. This device is not approved for custody transfer

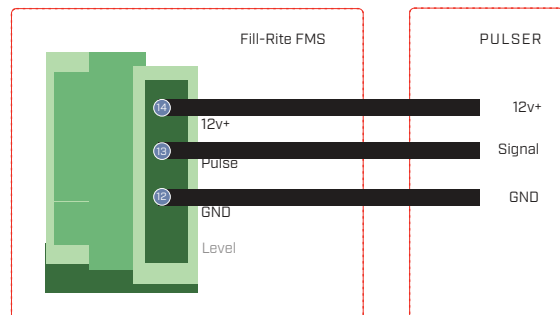
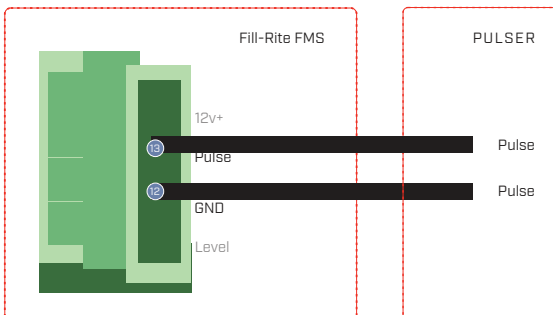

**Hardware Installation - Power On & Verification - NXFM100**

After installing the Fill-Rite FMS hardware and restoring power to the pump, verify the following items:

**1. Power to the Hardware: (AC Power)**

Check that the LEDs are illuminated on the Fill-Rite FMS circuit board. If the board does not have power, check that the local circuit breaker has not tripped.

**2. Bypass Mode:**

Flip the bypass switch to “ON” on the Fill-Rite FMS circuit board and confirm that your fuel equipment can dispense fuel. Be sure to switch to “NORMAL” mode after you have successfully tested your equipment.

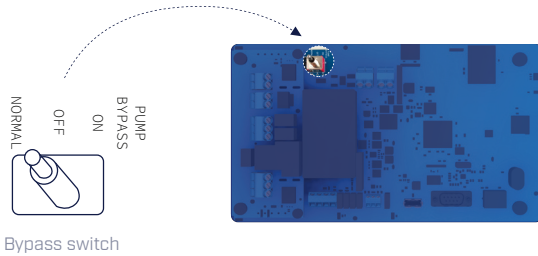

**3. Hardware WiFi:**

Ensure that your Fill-Rite FMS hardware is successfully broadcasting a wifi signal. On a wifi-enabled device, you should be able to identify and join a wifi network titled “NXFM\_XXXXX”, where XXXXX is the last five digits of the device’s serial number.

**4. Test Transaction:**

Have the Fill-Rite FMS administrator create a driver profile and pin code for you, and perform a test fueling using the Fill-Rite FMS mobile app. The Fill-Rite FMS app may perform a firmware update on first use.

**5. Check Pulse Rate:**

Confirm that the volume displayed on the Fill-Rite FMS app matches the volume of fluid being dispensed by the equipment. If the volumes do not match, go to [fms.fillrite.com](http://fms.fillrite.com), select the site in question, click on the configuration tab, and edit the pump/relay to update the pulse rate.

**Mounting Dimensions - NXFM100 & NXFM150**

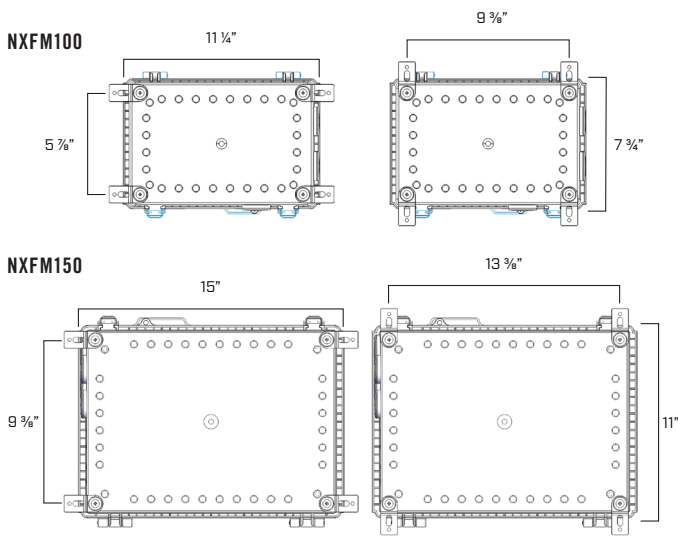

**Hardware Installation - NXFM150 Wiring**

**Fill-Rite FMS Hardware Power In / Power Out**

Fill-Rite FMS piggybacks power off of the Hose #1 power input. Your wiring configuration will depend on whether the pump runs on AC or DC power.

**Do Not** piggyback input or output wiring unless the wires are sized correctly via NEC

**DC**

**Ensure Power Select switch is in DC position\***

DC input requires ~12V DC. Attach positive power to DC+ (terminal 3), negative to DC- (terminal 2), and earth ground to (terminal 1) as demonstrated in Figure 1.

For output power, attach the positive load wire to DC+ output (terminal 28), negative to DC- (terminal 29), and earth ground to (terminal 30).

The NXFM150 hardware accepts up to 5 pumps or loads. For each additional pump, please connect the input and power out on channel 2 through 5.

**AC**

**Ensure Power Select switch is in AC position\***

AC input requires 80-240V AC. Attach Line power to L/DC+ (terminal 3), Neutral to N/DC- (terminal 2), and earth ground to (terminal 1).

For output power, attach the load line wire to the L/DC+ output (terminal 28), load Neutral to N/DC- (terminal 29), and earth ground to (terminal 30).

*\* Do Not switch AC/DC power mode either direction while unit is powered on*

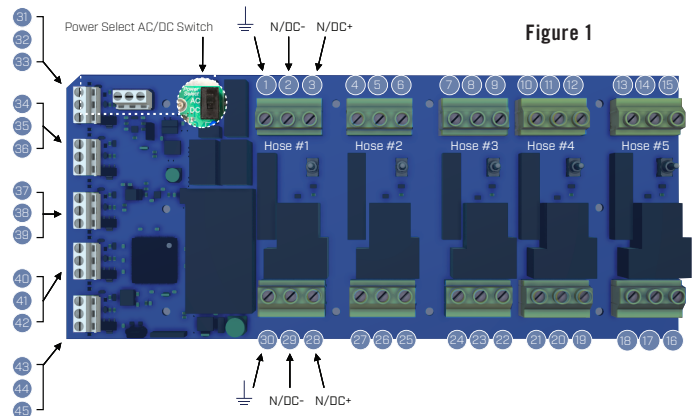

**RS-485**

The Site Controller and Expansion Module must be connected together through RS-485 in order to communicate. Both hardware units have 3 wiring terminals that must be connected to each other. A, B, and GND on the Site Controller need to be connected to A, B, and GND on the Expansion Module.

Multiple NXFM150 Modules can be linked together in a series (up to 10 modules) using RS-485.

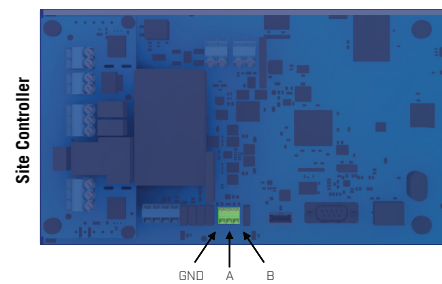

**RS-485 Expansion Module**

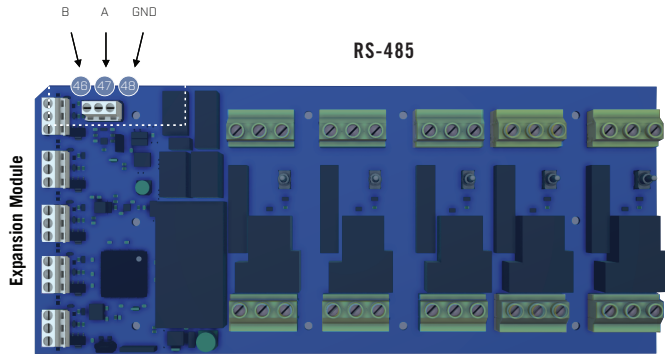

**Hardware Installation - Power On & Verification - NXFM150**

After installing the Fill-Rite FMS hardware and restoring power to the pump, verify the following items:

**1. Power to the Hardware: (AC Power)**

Check that the LEDs are illuminated on the Fill-Rite FMS circuit board. If the board does not have power, check that the local circuit breaker has not tripped.

**2. Bypass Mode:**

Flip the bypass switch to “BYPASS” on the Fill-Rite FMS circuit board, and confirm that your fuel equipment can dispense fuel. Be sure to switch to “NORMAL ON” mode after you have successfully tested your equipment.

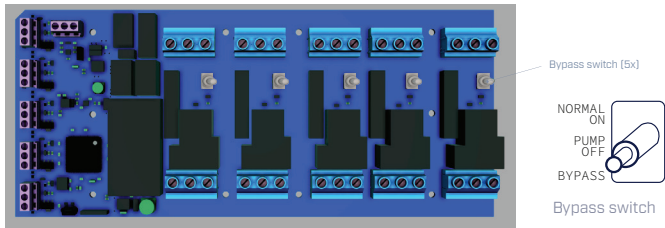

**3. Hardware WiFi:**

Ensure that your Fill-Rite FMS hardware is successfully broadcasting a wifi signal. On a wifi-enabled device, you should be able to identify and join a wifi network titled “NXFM\_XXXXX”, where XXXXX is the last five digits of the device’s serial number.

**4. Test Transaction:**

Have the Fill-Rite FMS administrator create a driver profile and pin code for you, and perform a test fueling using the Fill-Rite FMS mobile app. The Fill-Rite FMS app may perform a firmware update on first use.

**5. Check Pulse Rate:**

Confirm that the volume displayed on the Fill-Rite FMS app matches the volume of fluid being dispensed by the equipment.

If the volumes do not match, go to [fms.fillrite.com](https://fms.fillrite.com), select the site in question, click on the configuration tab, and edit the pump/relay to update the pulse rate.

**Hardware Installation - Pulsers - NXFM150**



- Do not attach AC power to the terminal marked “12V+”. This terminal is for DC active pulsers only. Attaching AC power to this terminal will destroy your Fill-Rite FMS board.

The wiring configuration for pulsers depends on whether you are using a 2 wire pulser or a 3 wire pulser. All Pump 1 pulser wiring should be connected to the terminals 31, 32, and 33 as demonstrated in the graphic below.

**2-Wire Pulser:** For 2 wire pulsers, it does not matter which of the two wires you attach to each terminal:

- Attach one wire to the terminal marked ENC INP - Terminal (32)
- Attach one wire to the terminal marked GND - Terminal (33)

**3-Wire Pulser:** Use 3 wire pulser if pulser requires 12V DC power:

- Attach 12V power line from the pulser to the ‘12V DC’ terminal - Terminal (31)
- Attach signal wire to the ENC INP terminal - Terminal (32)
- Attach the ground wire to the GND terminal - Terminal (33)

If using multiple NXFM150 Expansion Modules, use the potentiometer to assign each box an address

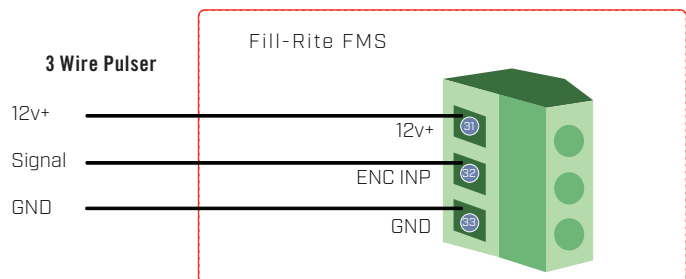
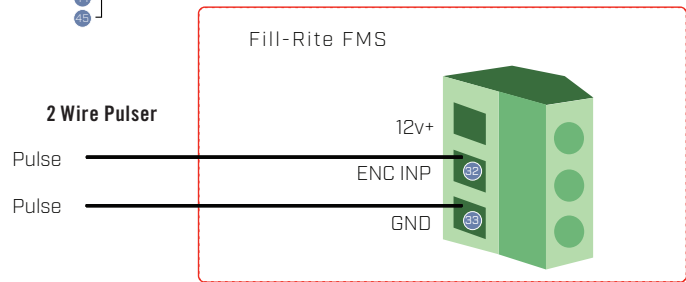
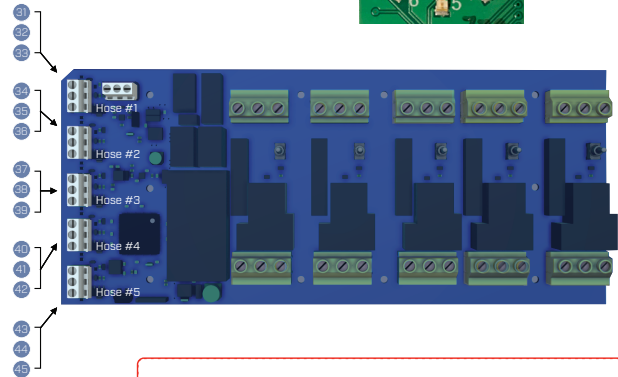
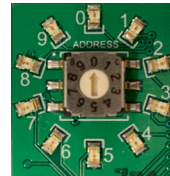

## Certifications / Approvals

### FuelCloud, Inc.

### Fill-Rite FMS - NXFM100

#### RATINGS:

Max Ambient Temperature Rating: 50 °C  
Input: 100-240VAC, 50/60 Hz 3600W  
8-50VDC, 1500W  
Output: 100-240VAC, 50/60 Hz  
125VAC 1HP  
240VAC 2HP  
125 VAC 30A General Purpose  
Enclosure: NEMA 4X



For supply connection use wires rated for at least 90C (194F)  
For use with equipment specified in the installation instructions.

### SEE INSTALLATION INSTRUCTIONS

WARNING SIGNAL WIRING IN THIS BOX MUST BE RATED AT LEAST 300V.

CAUTION: BONDING BETWEEN CONDUIT CONNECTIONS IS NOT AUTOMATIC AND MUST BE PROVIDED AS A PART OF THE INSTALLATION

ATTENTION: LE CABLAGE DE SIGNALISATION RACCORDÉ DANS CETTE DOITE DOIT CONVENIR POUR UNE TENSION NOMINALE D'AU MOINS 300V.

ATTENTION: L'INTERCONNEXION DES CONDUITS NE SUFFIT PAS POUR ASSURER LA MISE À LA MASSE; ELE DOIT FAIRE PARTIE INTEGRANTE DE L'INSTALLATION

This device complies with Part 15 of the FCC Rules. Operation is subject to the following two conditions: (1) this device may not cause harmful interference, and (2) this device must accept any interference received, including interference that may cause undesired operation.

### FuelCloud, Inc.

### Fill-Rite FMS - NXFM150

#### RATINGS:

Max Ambient Temperature Rating: 50 °C  
Input: 80-277VAC, 50/60 Hz 7.5A  
12VDC, 7.5A  
Output: 80-277VAC, 50/60 Hz 7.5A  
12VDC, 7.5A  
Enclosure: Type 4X



For supply connection use wires rated for at least 90C (194F)  
For use with equipment specified in the installation instructions.

### SEE INSTALLATION INSTRUCTIONS

WARNING SIGNAL WIRING IN THIS BOX MUST BE RATED AT LEAST 300V.

CAUTION: BONDING BETWEEN CONDUIT CONNECTIONS IS NOT AUTOMATIC AND MUST BE PROVIDED AS A PART OF THE INSTALLATION

ATTENTION: LE CABLAGE DE SIGNALISATION RACCORDÉ DANS CETTE DOITE DOIT CONVENIR POUR UNE TENSION NOMINALE D'AU MOINS 300V.

ATTENTION: L'INTERCONNEXION DES CONDUITS NE SUFFIT PAS POUR ASSURER LA MISE À LA MASSE; ELE DOIT FAIRE PARTIE INTEGRANTE DE L'INSTALLATION

This device complies with Part 15 of the FCC Rules. Operation is subject to the following two conditions: (1) this device may not cause harmful interference, and (2) this device must accept any interference received, including interference that may cause undesired operation.

# FILL-RITE®

Fill-Rite Company  
8825 Aviation Drive  
Fort Wayne, Indiana 46809 USA

T 1 (800) 720-5192  
1 (260) 747-7524  
F (800) 866-4681



fillrite.com | soteracom | gormanrupp.com