

# SOTERA KIT TECHNICAL DATA SHEET

FOR ALL 400B SERIES MODELS



KIT INFORMATION						
	DIAPHRAGMS	CLASSIFICATION	PART NUMBER	LIST NUMBER*	DESCRIPTION	
DIAPHRAGM REBUILDS	HYTREL	400A	400KTG6862	Not Shown	Rebuild Kit	
		400B	400KTH1179	18, 21, 22, 24, 25, 26, 27, 28	Diaphragms (Only)	
			400KTH1201	400KTH1179, 1, 2, 3, 4, 5, 6, 7, 8, 23	Rebuild Kit, Includes Body, No Motor	
			400KTH1456	400KTH1179, 2, 3, 4, 5, 6, 7, 8, 23	Rebuild Kit Less Body, No Motor	
	SANTOPRENE	400A	400KTG6863	Not Shown	Rebuild Kit	
			400KTG9137		Diaphragms (Only)	
		400B	400KTH1178	18, 21, 22, 24, 25, 26, 27, 28	Diaphragms (Only)	
			400KTH1200	400KTH1178, 1, 2, 3, 4, 5, 6, 7, 8, 23	Rebuild Kit, Includes Body, No Motor	
			400KTH1457	400KTH1178, 2, 3, 4, 5, 6, 7, 8, 23	Rebuild Kit Less Body, No Motor	
	VOLTAGE	CLASSIFICATION	PART NUMBER	LIST NUMBER*	DESCRIPTION	
MOTOR REPLACEMENT	12V DC	STANDARD, NON-EXP	400G9734	16B	Motor Assembly with Gear Pack	
		UL CERT, EXP	400EXPF6846	16A		
		CE CERT, EXP	KITS400MS12VCE			
	24V DC	UL CERT, EXP	KITS400MS24VUL			
	115V AC	STANDARD, NON-EXP	400G9735	16B		
		UL CERT, EXP	400EXPF7351	16A		
	INLET	CLASSIFICATION**	PART NUMBER	LIST NUMBER*	DESCRIPTION	
FLANGES, ADAPTERS, TUBES, HOSE, SPOUTS	SUCTION	AA	400F6569	19 (will vary by pump model)	Flange Straight Plastic w/ Inserts	
			400G9140		Bung Adapter 400 Machined Painted (Black)	
		BB	400G9493		Flange Metal SAE Threads, Anodized	
		CC	400G8071		Flange 2" NPT Pump	
		DD	400KTG8106		Quick Attach Kit, 2" NPT & Buttress	
			400KTG8583		Quick Attach Cap	
			400KTG9028		Quick Attach 2" NPT Adapter	
			400KTG9029		Quick Attach 2" Buttress Adapter	
		EE	400F6679		900 Inlet, NPT Threads	
			KITS400FLGBSP		900 Inlet, BSPP Threads	
		TUBE	1200KTG9099		Steel Extendable Suction Tube	
			400F1855		Poly Extendable Suction Tube	
	4451863		Poly Extendable Suction Tube w/ Bellows End			
	IBC	400KTG9342	Top Suction Kit			
		400KTG9341	Bottom Suction Kit			
	DISCHARGE	HOSE	400KTG8830		Not Shown	825 Meter w/ 1" x 12' EPDM Hose (Assembled)
		SPOUT	400KTF0237			Anti-Drip Nozzle Spout Kit

\*Refer to page 4, Kit Parts List by Contents table, for details

\*\*Refer to page 1 of the Sotera Technical Data Sheet, Suction table, for inlet configuration classification details

## KIT INFORMATION (CONT.)

	CLASSIFICATION	PART NUMBER	LIST NUMBER*	DESCRIPTION
MISCELLANEOUS	MECHANICAL	400F6557	12	Mechanical Gear Pack
		400F6781	23	Internal Yoke Assembly
		400H1401	2, 3	Site Cap Assembly
		400KTF6867	Not Shown	Wheels, Chemtraveller® (Tall Frame)
	SEALS & VALVES	445KTG9128	Not Shown	445 EPDM Seal Kit
		445KTH1492		445 Recirculation Valve Rebuild (Only)

\*Refer to page 4, Kit Parts List by Contents table, for details

## ACCESSORIES INFORMATION

	ACCESSORY TYPE	PART NUMBER	DESCRIPTION
ACCESSORIES	DIGITAL METER	825	1" w/ Fluorocarbon Seals, NPT
		825X700	1" w/ EPDM, NPT
		825P	1" w/ Pulse Output, Fluorocarbon, NPT
		850	1" w/ Air Sensor, Fluorocarbon, NPT
		850P	1" w/ Air Sensor, Pulse Output, Fluorocarbon, NPT
		825D075BSPPS	3/4", DEF, BSPP
		TT10PN	1" In-Line Turbine Meter, Polymer Body, NPT
		TT10PB	1" In-Line Turbine Meter, Polymer Body, BSPP
	NOZZLE	FRHMN100S	1" Nozzle Manual, Aluminum
		400G7006	1" Valve Nozzle, Polypropylene
		400KTF0237	1" Anti-Drip Spout Kit, Viton
		435G9126	1" Anti-Drip Spout Kit, EPDM
	HOSE	700F3123	1" x 12', EPDM Discharge
		435F3455	1" x 9', EPDM Suction
		400H0547	1" x 39', EPDM Suction
		FRH10012	1" x 12', Nitrile Discharge
		FRH10014	1" x 14', Nitrile Discharge
		FRH10020	1" x 20', Nitrile Discharge
	SWIVEL	S100H1315	1" Multi-Plane

### INLET KITS

KIT NUMBER	DESCRIPTION	INCLUDES*
400KTG8106	Quick Attach Kit, 2" NPT and Buttress	F-0, R
400KTG8583	Quick Attach Cap	F, H
400KTG9028	Quick Attach 2" NPT Adapter	O, F, H, R
400KTG9029	Quick Attach 2" Buttress Adapter	N, F, H, R

### SUCTION TUBE OPTIONS

PART NUMBER	DESCRIPTION	QTY
1200KTG9099	Steel Extendable Suction Tube	1
400F1855	Poly Extendable Suction Tube	1
445F1863	Poly Extendable Suction Tube w/ Bellows End	1

\*Refer to Sotera 400B Series Owner's Operation Manual for details

## SS435 CHEMTRAVELLER

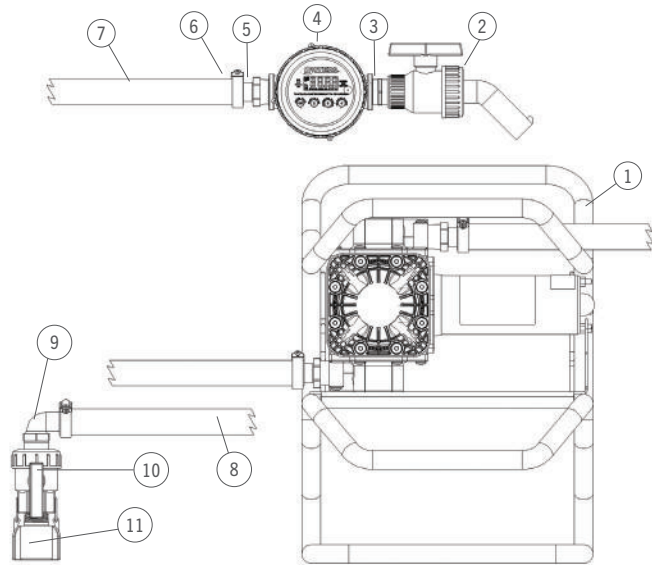

ITEM	DESCRIPTION
1	Short Frame
2	1" Valve/Nozzle
3	1" Poly Short Nipple
4	825 Meter
5	1" Hose Barb
6	Hose Clamp
7	1" x 12' EPDM Discharge Hose
8	1" x 9' EPDM Suction Hose
9	1" Poly Street Elbow
10	1" Ball Valve

## SS465 CHEMTRAVELLER

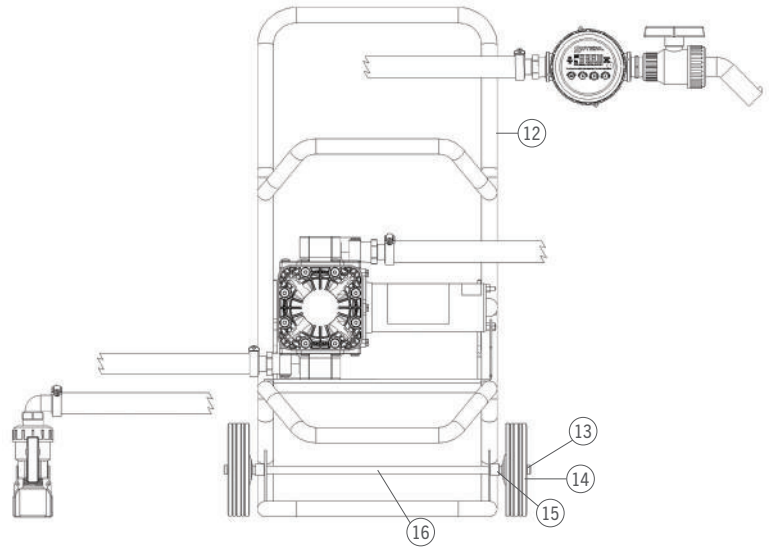

ITEM	DESCRIPTION
11	1" Female Coupler
12	Tall Frame
13	Push Nut
14	Wheel, 6" x 1.5"
15	Spacer
16	Shaft, 1/2" Diameter x 19.5" Long
17	1" Male Adaptor
18	Double Tap Bushing
19	Suction Tube
20	2" Female Coupler

ITEM	DESCRIPTION
21	2" Male Coupler
22	2" x 1" Reducer Brushing

KIT NUMBER	INCLUDES
400KTG8830	2, 3, 4, 5, (2) 6, 7
400KTG9342	17, 11, 10, 18, 9, 445F1863 Suction Tube
400KTG9341	20, 21, 22, 3, 10
400KTF6867	(2) 13, (2) 14, (2), 15, 16
400KTF6853	12, 400F6679 Flange & Hardware

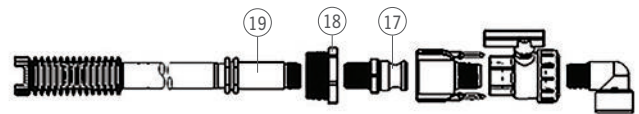
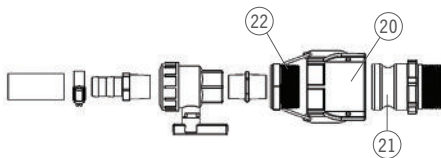

### KIT 400KTG9341 INSTRUCTIONS

1. Use PTFE tape or thread sealant on all joints.
2. Thread 2" cam adaptor (item 21) into tank discharge valve and tighten.
3. Assemble remaining fittings as shown.
4. Close valve on pump outlet hose.
5. Connect cam adapter (item 21) on suction hose to tank.
6. Open tank valve, then open suction hose valve.
7. Close tank valve when dispensing is complete.

### KIT 400KTG9342 INSTRUCTIONS

1. Use PTFE tape or thread sealant on all joints.
2. Install suction tube (item 19) and adapter (item 17) into brushing (item 18) and tighten.
3. Extend suction tube (item 19) to required length, then install brushing (item 18) on drum.
4. Install other components as shown.
5. Engage coupler adapter and open ball valve.
6. Close ball valve and disconnect coupler to remove.

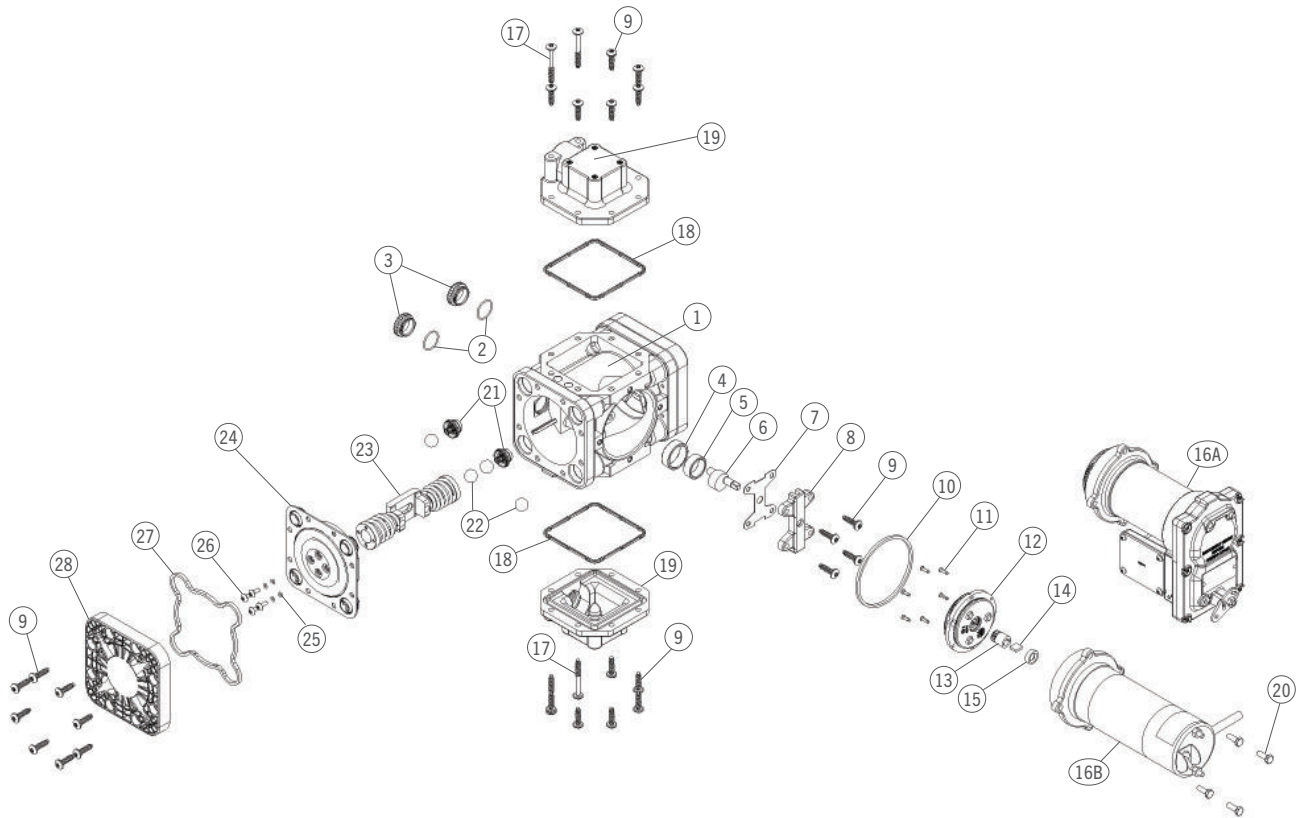

### KIT PARTS LIST BY CONTENTS

ITEM	DESCRIPTION	QTY	ITEM	DESCRIPTION	QTY
1	Pump Body	1	15	Shaft Lip Seal, 400 Motor Shaft	1
2	O-Ring Nitrile, -022	2	16A, 16B	Motor Assembly (see charts below for motor specifics)	1
3	Sight Cap	2	17	Screw, ¼ - 10 x 2.25 PTS-SS	4
4	Bearing Ring	1	18	Flange Gasket - EPDM	2
5	Brushing, 1.250 OD. x 1.00 ID.	1	19	90° Flange with Inserts	2
6	Drive Shaft	1	20	Screw, ¼ - 20 x .750 LG	4
7	Thrust Plate	1	21	Outlet Check Valve	4
8	Bearing Plate	1	22	Ball	8
9	Screw, ¼ - 10 x 1.00 PTS-SS	32	23	Yoke Assembly	1
10	O-Ring, Lathe Cut Nitrile	1	24	Diaphragm Assembly	2
11	Screw, 6-32 Flat Head Trilobular	6	25	O-Ring, EPDM, -007	8
12	Gear Pack Assembly	1	26	PHM Screw, 10 - 24 x .5 LG	8
13	Drive Gear	1	27	Diaphragm Cover Gasket - EPDM	2
14	Key, Rotor	1	28	Diaphragm Covers	2

ITEM	UL LISTED / CE CERTIFIED MOTORS	QTY
16A	12V DC CE Compliant Explosion Proof	1
16A	12V DC UL Listed Explosion Proof	1
16A	24V DC UL Listed Explosion Proof	1
16A	115V AC UL Listed Explosion Proof	1

ITEM	STANDARD-DUTY MOTORS	QTY
16B	12V DC	1
16B	115V AC	1

SOT-DS-897v.1