

Part # 40001

CENTURION HOUSINGS

Centurion Single

 **MADE IN USA**



Compatibility

Gasoline, diesel, biodiesel up to B20, ULSD, ethanol blends up to 15%, and industrial fluids such as lube oils, hydraulic oils, synthetic oils, and many solvents

Features

- Drain for easy water removal
- For use with element part # 30002, 30004, 30033, 30036, 30065, and 30195

Specifications

1" NPT IN/OUT

USES 1 ELEMENT

30 GPM (113.6 LPM) MAX FLOW

50 PSI (3.4 BAR) MAX WORKING PRESSURE

NOT FOR USE WITH AVIATION APPLICATIONS

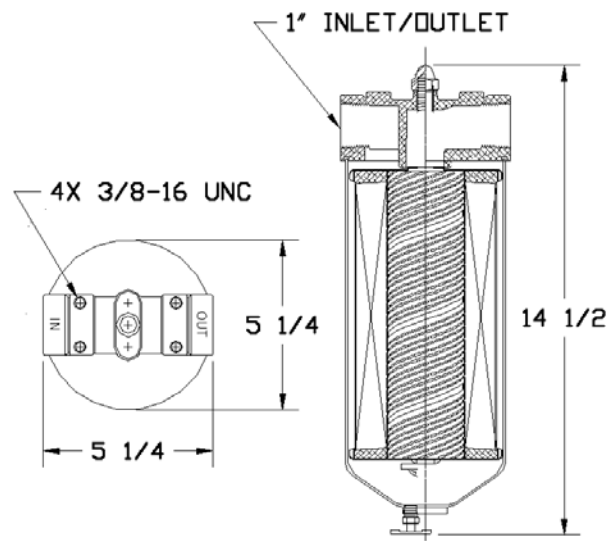

☎ 844.447.7663 🌐 www.cim-tek.com

INFORMATION SUBJECT TO CHANGE

#CH-001

12.22.23 Rev. C

